



Paul Meier Institut – Technical Division

Engineering + Industrial Services

Engineering | Technical Services | Spare Parts | System Controlling

Paul Meier and his team have been operating for over 40 years in industrial plant engineering and particularly in the area of coating machines for paper, film and non woven products

PMI designs, builds and repairs parts of your equipment and supplies spare components. We are on site and ensure the original manufacture or an improved version.

But the most important service component is in any case that we bring the experience and knowledge to optimize your system to repair or to procure the spare parts

New designs and developments

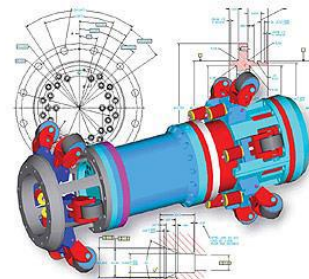

After the technical meeting, the solution is shown. Once the customer has released the “green light”, The manufacturing process is started

Technical analysis and check up of process conditions



In case of production problems or if you need an improvement, our PMI technician will come to your site and assist with his experience to solve the technical problem.

Complete construction in our factory or by one of our partner manufacturers

$$Q/A = K(T_{\text{SURFACE}} - T_{\text{DEPTH}}) / \text{EQUIV}_L$$

where:

Q/A = Heat Flow or Heat Flux BTU/Hr-ft²

K = Thermal Conductivity of the Meter Material

BTU-in/ft²-hr-F.

T_{SURFACE} = Surface Thermocouple Temperature, F.

F.

T_{DEPTH} = Depth Thermocouple Temperature, F.

EQUIV_L = Equivalent Thickness between

Surface and

Depth Thermocouples. Inch

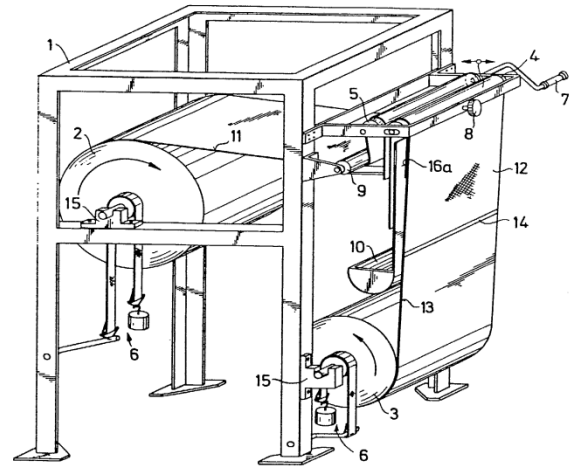

The idea of the customer or a new construction can be visualized with a layout and presented to the customer. If you agree the parts are manufactured in one of the PMI works or a partner company. The quality is guaranteed by the final quality checked by our standard PMI – Process.

From design to completion



Turning | Welding | Assembly | Check



Paul Meier himself was over 40 years as an executive engineer and technical director, worldwide in charge on the field of paper, film/foil and coating systems.

He and his team are available for trouble - shooting, service and spare parts deliveries as well, as new designs or technical advice.



We are always available with help and advice. We will be happy to answer any questions and we would like to support you in any kind of technical problems.



Service centers are located in:
Switzerland – Italy - Germany

Kontakt:

Tel: +41 79 437 66 94
Service: +41 71 982 72 72
Email: meier@omb.ch

